

# **5-Band Super Thunderbird**

**Model TH-11DX  
Instruction Manual**

***hy-gain***<sup>®</sup>

**308 Industrial Park Road  
Starkville, MS 39759 USA  
PH: 662-323-9538 FAX: 662-323-6551**



Please record the following information for your records:

Date of Purchase: \_\_\_\_\_

Purchased From: \_\_\_\_\_

Price Paid: \_\_\_\_\_

Please retain your copy of the Bill-of-Sale for warranty claims.

## TABLE OF CONTENTS

	<b>Page</b>
<b>CHAPTER 1</b> .....	1-1
General Description .....	1-1
Specifications .....	1-1
Theory of Operation .....	1-2
<b>CHAPTER 2</b> .....	2-1
Preparation for Assembly .....	2-1
<b>CHAPTER 3</b> .....	3-1
Assembly of the Boom and Boom-to-Mast Brackets .....	3-1
Assembly of the Element-to-Boom Brackets on the Boom .....	3-2
Installation of Tubing Clamps on Elements .....	3-3
Element Assembly .....	3-5
Installing Elements on the Boom .....	3-9
Phasing Tube Assembly .....	3-9
Boom Support Assembly .....	3-13
<b>CHAPTER 4</b> .....	4-1
Antenna Installation .....	4-1
Installation on a Crank-Up Tower .....	4-1
Other Types of Towers .....	4-1
Attachment of Feedline .....	4-1
Attaching the Antenna to the Mast .....	4-1
Lightning Protection .....	4-2
VSWR Curves .....	4-2
VSWR Charts .....	4-3
<b>CHAPTER 5</b> .....	5-1
Operation .....	5-1
Maintenance .....	5-2
<b>CHAPTER 6</b> .....	6-1
Troubleshooting .....	6-1
Troubleshooting Chart .....	6-1

# TABLE OF CONTENTS (Cont.)

	<b>Page</b>
<b>CHAPTER 7</b> .....	7-1
Service Information.....	7-1
Converting American Measurements to metric .....	7-2
Bolt and Nut Sizes.....	7-2
<b>Chapter 8</b> .....	8-1
Parts List .....	8-1

## LIST OF ILLUSTRATIONS

<b>Figure</b>		<b>Page</b>
1	Boom-to-Mast Bracket .....	3-1
2	Assembly of Boom and Element Spacings .....	3-2
3	Element-to-Boom Brackets .....	3-3
4	Tubing Clamps .....	3-4
5	Element Section Description .....	3-6
6	Exposed Tubing Lengths .....	3-7
7	Rope Dampener .....	3-8
8	Trap Detail .....	3-8
9	Phasing Tube Assembly.....	3-10
10	20 and 17 Meter Pigtail Wire Attachment .....	3-11
11	10, 12, 15 Meter Pigtail wire and Balun Attachment.....	3-12
12	Boom Support Assembly .....	3-13

# CHAPTER 1

## General Description

The Hy-Gain TH11DX is an 11-element, 5-band beam antenna designed for broadband, high-performance operation on the amateur 10,12,15,17, and 20 meter bands. The TH11DX features a log-periodic dipole driven array for all bands with monoband reflectors for 17 and 20 meters and trapped directors for 10,15,17 and 20 meters.

The TH11DX is supplied with the new Hy-Gain BN-4000 high power balun. These standard features contribute to produce a maximum power rating of 2000 watts continuous-duty, 4000 watts PEP on all modes. The TH11DX also features an improved wire boom support system. All-stainless-steel hardware and clamps are used on all electrical connections.

## Specifications

### *Electrical:*

Bands.....	20,17,15,12,10 meters
Bandwidths (2:1 VSWR)	
20 meter .....	350 KHz
17 meter .....	100 KHz
15 meter .....	450 KHz
12 meter .....	100 KHz
10 meter .....	1200 KHz
Maximum Front-to-Back Ratio	
20 meter .....	27 dB
17 meter .....	22 dB
15 meter .....	25 dB
12 meter .....	15 dB
10 meter .....	19 dB
Maximum Gain	
20 meter .....	8.6 dBi (6.4 dBd)
17 meter .....	8.4 dBi (6.2 dBd)
15 meter .....	8.1 dBi (5.9 dBd)
12 meter .....	7.5 dBi (5.3 dBd)
10 meter .....	9.2 dBi (7.0 dBd)
Maximum Power.....	2000 watts Avg. 4000 watts PEP all modes
Recommended Transmission Lines .....	RG-213/u, Belden 8267

**NOTE:** Belden 9913 is NOT recommended.

## Specifications (Continued)

### *Mechanical:*

Boom Length .....	24 feet (7.32 m)
Boom Diameter .....	2 inches (5.1 cm)
Longest Element .....	37 feet (11.28 m)
Turning Radius.....	22 feet (6.7 m)
Accepts Mast.....	1.9" OD to 2.5" OD (51 to 64 mm)
Net Weight.....	88 lbs. (40.0 kg)
Shipping Weight .....	98 lbs. (44.5 kg)
Maximum Wind Survival (no ice)	
Boom:.....	119 mph (192 kmph)
Elements:.....	99 mph (159 kmph)
Wind Surface Area (max) .....	12.5 sq. ft. (1.1 sq. m)
Maximum Wind Load at 99 mph.....	490 lbs. (222 kg)
Element Tubing Clamps.....	All Stainless Steel
Hardware.....	All Stainless Steel
Boom Support.....	0.125 inch galvanized aircraft cable
Suitable Rotators .....	Hy-Gain HDR-300,T2X or Ham IV

## Theory of Operation

The TH11DX uses a 6 element log-periodic dipole array as the driven-element array. This provides a very low loss, high power driven array with moderate directivity above 18 MHz. Two resonant driven elements on 10 meters gives broad bandwidth on 10 meters and greater F/B on 12 meters.

Separate single-band reflectors on 17 and 20 meters provide excellent F/B. Trapped directors operate on 10, 15, 17, and 20 meters. Two of the three directors use 10 meter traps for less inductive loading and less loss. Directivity on the 12 meter band comes entirely from the log-periodic array, since a director for 12 meters would act like a reflector on 10 meters.

# CHAPTER 2

## Preparation for Assembly

**FOR OUR OVERSEAS CUSTOMERS:** The United States uses American units of measurement. Please see page 7-2 of this manual for American-to-metric conversion.

When unpacking your antenna, check inside of all tubing for smaller parts and traps. To conserve space, these smaller parts are sometimes packed inside larger pieces. Check all parts against the parts list to ensure no parts are missing. The hardware supplied with this antenna is bagged by thread size for your convenience.

You may want to sort the aluminum tubing for the elements before assembly. This makes element assembly much easier. The following table shows the various element tubing sizes and quantities.

Tubing Size	Quantity Shipped
1-1/4" x 48" w/insert	2
1-1/4" x 35" w/insert	2
1-1/4" x 35"	10
1-1/8" x 48"	6
1-1/8" x 38"	8
1" x 21 1/2"	2
7/8" x 55"	6
7/8" x 44"	6
7/8" x 24"	4
5/8" x 26"	16
7/16" x 62"	2
7/16" x 58"	4
7/16" x 55"	6
7/16" x 42 3/4"	4
7/16" x 17-1/8"	2
7/16" x 68"	2

Choose a large, clear area to assemble your TH11DX antenna. The area must be at least 24' x 37' (7.3m x 11.3m). You may wish to use a temporary mast or sawhorses to support the boom during assembly.

A concrete driveway is an excellent area for assembly. If you assemble this antenna over a grassy area, precautions should be taken so that hardware is not accidentally lost during assembly. We have included some extra small parts with this product, just in case some are lost.

All tubing supplied with the TH11DX telescopes together. Make all measurements to the given dimensions, plus or minus, no more than 1/8 inch.

**TOOLS:** The following tools are required for easy assembly of the TH11DX:

Type Tool	Qty
Tape Measure, 12 foot.....	1
Adjustable Wrench, 8 inch.....	2
Nut Driver, 7/16".....	1
Nut Driver, 3/8".....	1
Nut Driver, 5/16".....	1
Nut Driver, 1/2".....	1

We suggest that the assembly of this product be done over a 2 day period. We further suggest that you read this manual thoroughly, in its entirety, and then go through the manual a second time and identify and familiarize yourself with all of the antenna components. Start assembling the antenna when you are prepared. A few hours invested in the assembly process will ensure many years of satisfaction with the TH11DX.

**NOTE:** An extra page that contains Figures 5 and 6, Element Section description and Exposed Tubing Lengths, has been inserted in this manual for use when assembling the antenna.

If you live near a sea coast, please follow the additional instructions contained in the "Maintenance" section of this manual.

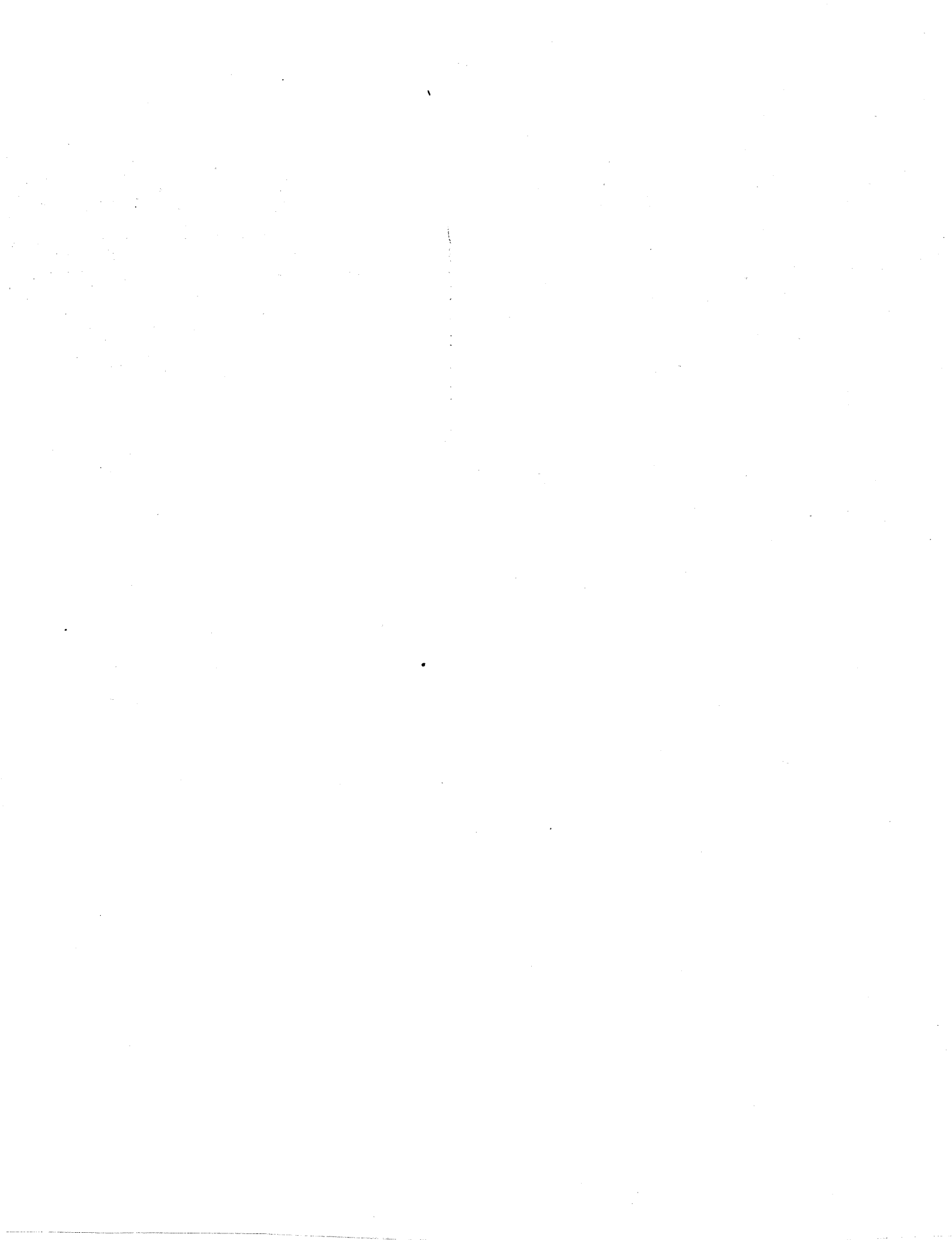



# CHAPTER 3

## Assembly of the Boom and Boom-to-Mast Brackets

Select the boom-to-bracket clamp parts (Item Nos. 89 & 90). Loosely assemble them on the boom ends (Item No. 79), as shown in Figure 1. Line up the holes on both brackets and both boom ends. Secure the two brackets together with four (4) 1/4"-20 x 3/4" bolts, lockwashers and nuts (Item Nos. 34,39, and 38). Secure the brackets to the two boom ends using the 5/16"-18 x 2 3/4" bolts, lockwashers and nuts (Item Nos. 28, 31 and 29). Tighten these six bolts securely. The casting-to-boom bracket (Item No. 90) may deform slightly when the four 1/4"-20 x 3/4" bolts are tightened; this is normal.

### NOTE:

If you use a galvanized 1 1/2" schedule 40 or 80 pipe as a mast, it has an O.D. of 1.9". You will need to put two split lockwashers under the 5/16 nuts on the four long bolts.

Assemble the two cast aluminum brackets (Item No. 82) on your temporary mast at about 4 feet above ground. A five-foot length of 2" ABS or PVC plastic drain pipe makes an inexpensive temporary mast. Secure the two brackets together using the two (2) 5/16"-18 x 3" bolts, lockwashers and nuts (Item Nos. 27, 31 and 29). Tighten these two bolts evenly until the brackets are snug.

You should drill a 5/16" hole through the mast at the center hole of the mast bracket and secure using a 5/16"-18 x 4" bolt, lockwasher, and nut. (Item No.s 30, 31 and 29). This bolt will prevent the antenna from twisting on the mast in high winds. See Figure 1.

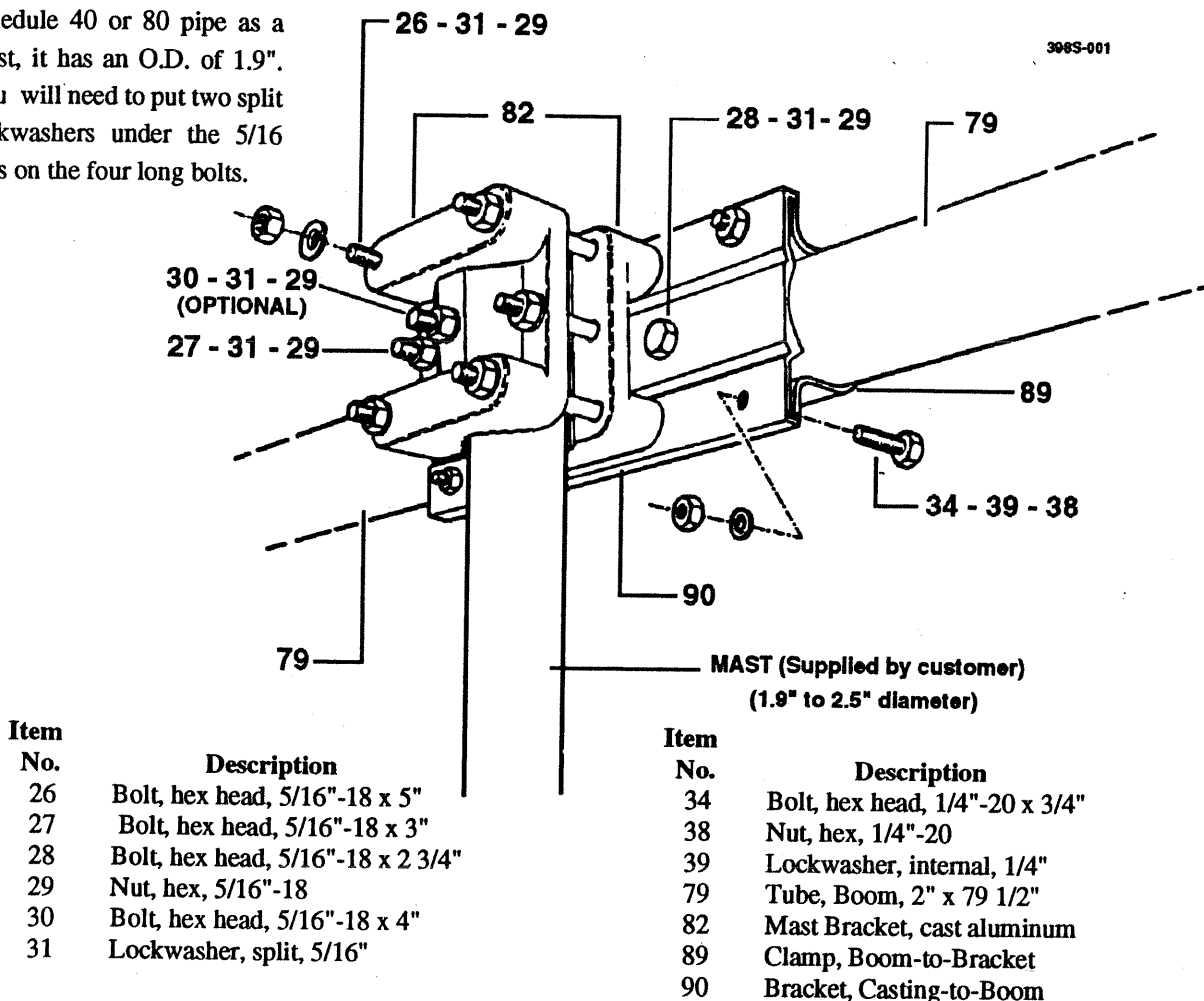

**Figure 1**  
**Boom-to-Mast Bracket**

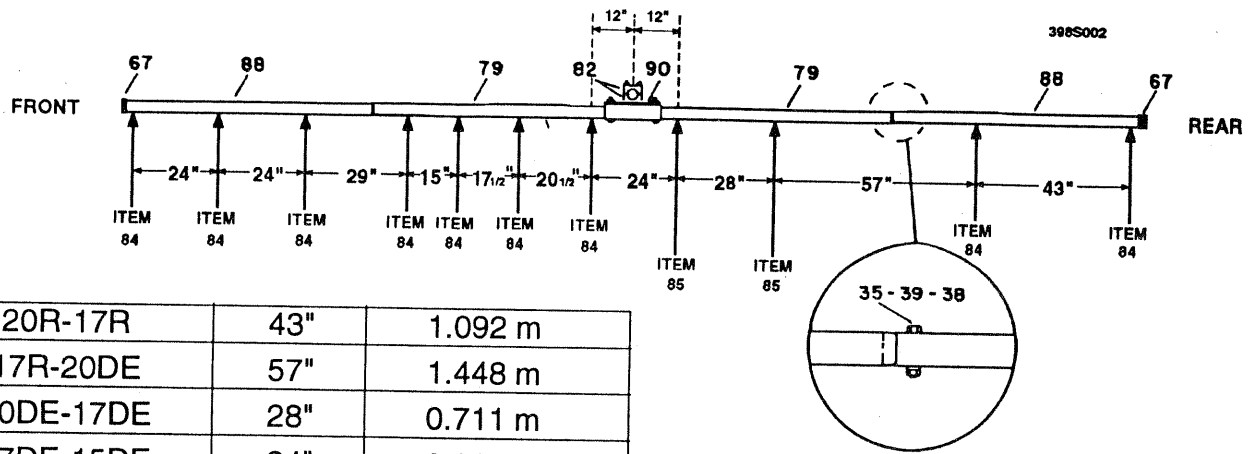

20R-17R	43"	1.092 m
17R-20DE	57"	1.448 m
20DE-17DE	28"	0.711 m
17DE-15DE	24"	0.610 m
15DE-12DE	20.5"	0.521 m
12DE-R10DE	17.5"	0.445 m
R10DE-R10DE	15"	0.381 m
F10DE-15D	29"	0.737 m
15D-20D	24"	0.610 m
20D-17D	24"	0.610 m

Item No.	Description
35	Bolt, hex head, 1/4"-20 x 2 1/2"
38	Nut, hex, 1/4"-20
39	Lockwasher, internal, 1/4"
67	Caplug, 2"
79	Tube, Boom, 2" x 79 1/2"

Item No.	Description
82	Mast Bracket, cast aluminum
88	Tube, Boom, 2" x 69 1/2"
89	Clamp, Boom-to-Bracket
90	Bracket, Casting-to-Boom

**Figure 2**  
**Assembly of Boom and Element Spacing**

Attach the boom and bracket assembly to these two brackets using the four (4) 5/16"-18 x 5" bolts, lockwashers and nuts (Item Nos. 26, 31, and 29) as shown in Figure 1. If you have problems aligning all of the holes in the brackets, you may wish to carefully run a 5/16" drill bit through these holes. Do not enlarge these holes beyond 5/16" or you may weaken the brackets. This will prevent alignment problems that might occur on the top of your tower! Tighten these four bolts just enough to hold the weight of the antenna.

Slip the two remaining boom sections (Item No. 88) over the two swaged ends of the assembled boom and secure using a 1/4"-20 x 2 1/2" bolt, lockwasher and nut (Item Nos. 35, 39 and 38), as shown in Figure 2.

### Assembly of the Element-to-Boom Brackets on the Boom

There are two sizes of element-to-boom brackets supplied with the TH11DX antenna. The largest (Item No. 85) has a 1 1/2" I.D., and is used only on the two longest driven elements. The remaining brackets (Item No. 84) have a 1 1/4" I.D., and are used on both the four front driven elements and the parasitic elements.

The largest brackets (Item No. 85) are stamped with the number 14, while the smaller brackets (Item No. 84) are stamped with the number 13.

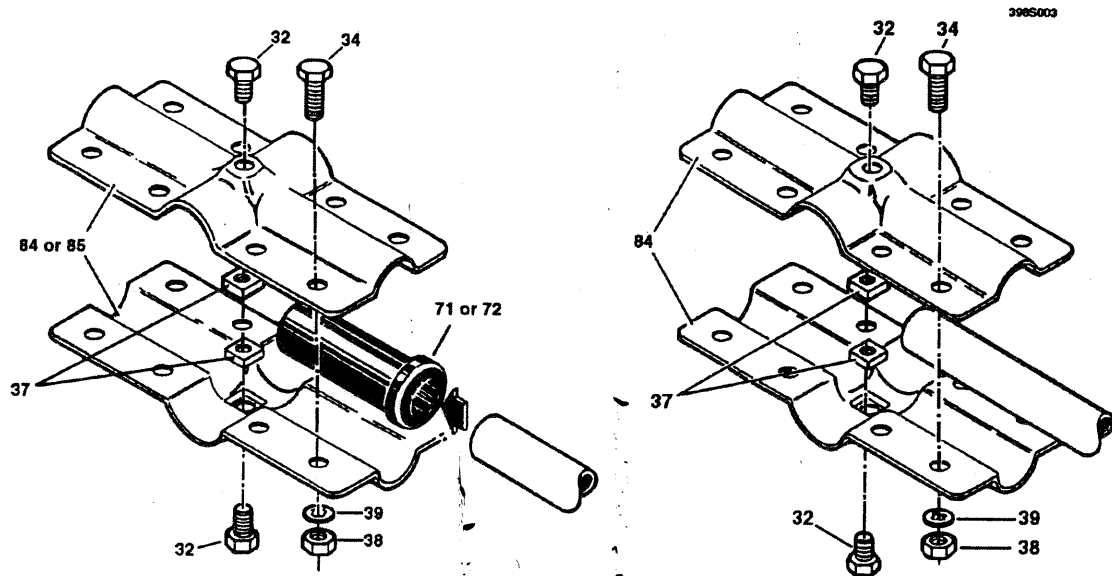

Item No.	Description
32	Bolt, hex head, 1/4"-20 x 3/8"
34	Bolt, hex head, 1/4"-20 x 3/4"
37	Nut, square, 1/4"-20
38	Nut, hex, 1/4"-20

Item No.	Description
39	Lockwasher, internal, 1/4"
71	Insulator, Driven Element, 1 1/2" O.D.
72	Insulator, Driven Element, 1 1/4" O.D.
84	Bracket, Element-to-Boom, #13
85	Bracket, Element-to-Boom, #14

**Figure 3**  
**Element-to-Boom Brackets**

Assemble the brackets as shown in Figure 3 and locate them on the boom assembly as shown in Figure 2. It is easier to assemble the brackets on the boom at the correct location, rather than try to slide them on the boom. If you are going to leave this assembly unattended for more than 15 minutes, we suggest that you tighten the eight (8) bolts on each bracket, so that they do not vibrate off. Do not tighten the two (2) anchor bolts (Item No. 32) until the elements are installed and aligned.

**Do not install the top anchor bolts in the 17DE, 15DE, 12DE, and R10DE brackets.** The phasing tubes will be installed over these brackets in a later step, and the top anchor bolts may short the phasing tubes at these element locations.

You may want to mark the bracket location on the boom with an indelible marker. You can quickly realign the brackets to these marks when you install the elements to the brackets in a later step.

### Installation of Tubing Clamps on Elements

Select the proper size tubing clamps as shown in the Figure 4. When installing the clamps, place the clamp near the tube end with the top of the clamp over the slot in the tube as shown in Figure 4. After adjustment of the tubing lengths, tighten the clamp with a 5/16 inch nut driver, socket, or open end wrench until the tubing will not twist or telescope. **DO NOT** overtighten! Also, if you loosen and tighten a clamp more than 5 times, we suggest that you replace the clamp. After repeated tightenings, these clamps may become difficult to completely tighten. Should you need to replace these clamps, use only high quality stainless steel clamps to ensure proper torque.

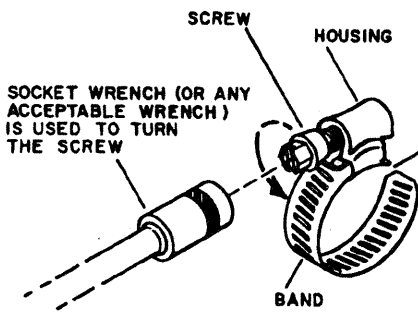

MA-0000-A-068

THE BAND CAN BE OPENED TO PLACE THE CLAMP ON THE ELEMENT TUBING

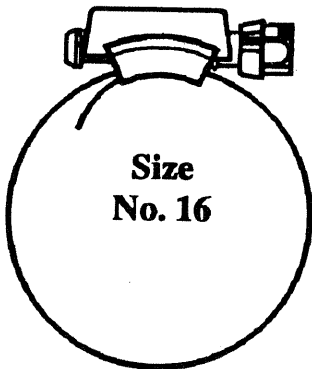
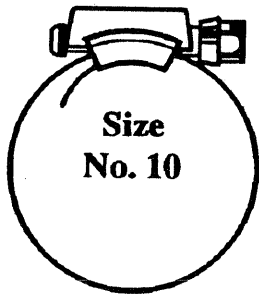
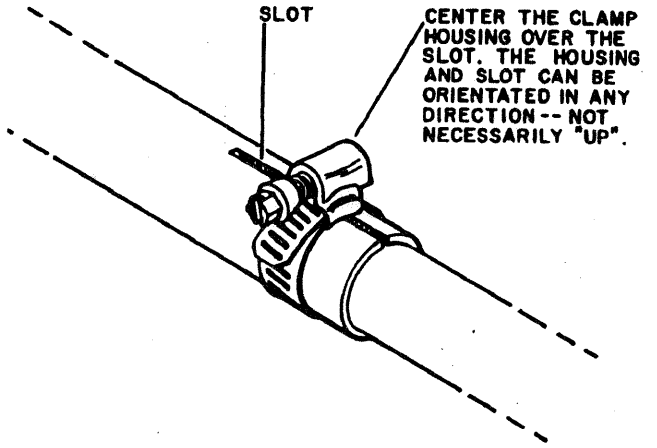

Part No.	Description	Fit Tubing Sizes
358756	Clamp, Size #6 all stainless steel 5/16" hex head screw	1/2 and 3/4"

Part No.	Description	Fits Tubing Sizes
358757	Clamp, Size #10 all stainless steel 5/16" hex head screw	1"

Part No.	Description	Fits Tubing Sizes
358758	Clamp, Size #16 all stainless steel 5/16" hex head screw	1 1/4"

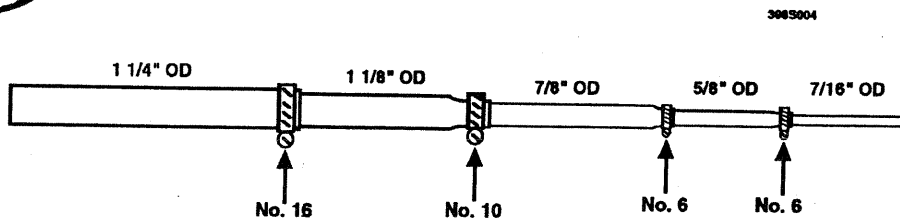

Figure 4  
Tubing Clamps

## Element Assembly

The TH11DX can be optimized for three different settings. The "Phone" setting optimizes both the VSWR and patterns for the US phone section of each band, and is also the preferred setting for full-band coverage. The "DX" setting optimizes both the VSWR and patterns for the low end of each band including the US CW sections. This is generally the best setting for overseas use. The "MARS" setting provides broader VSWR bandwidths for the 20 and 15 meter bands, without affecting the other bands. There is no difference between settings on the 12 and 17 meter WARC bands, since they are very narrow. When you assemble the elements use the following table to set the TH11DX to one of the three settings. See page 4-3 for typical VSWR charts.

The element abbreviations and descriptions are:

20R	=	20 meter reflector
17R	=	17 meter reflector
20DE	=	20 meter driven element
17DE	=	17 meter driven element
15DE	=	15 meter driven element
12DE	=	12 meter driven element
R10DE	=	rear 10 meter driven element
F10DE	=	front 10 meter driven element
15D	=	10/15 meter director
20D	=	10/20 meter director
17D	=	10/17 meter director

Assemble the elements in this order. Select the tubing for the two 20R element halves and assemble them as shown in Figure 5. Do not tighten the clamps yet.

Dimension	Phone Setting	DX Setting	MARS Setting
A	53.50" (1.359 m)	54.50" (1.38 m)	54.50" (1.38 m)
B	53.25" (1.353 m)	56" (1.42 m)	56" (1.42 m)
C	46" (1.168 m)	45.50" (1.156 m)	45.50" (1.156 m)
D	25" (0.635 m)	26.50" (0.673 m)	26.50" (0.673 m)
E	22.25" (0.565 m)	22.50" (0.572 m)	21.50" (0.546 m)
F	80.625" (2.048 m)	81.625" (2.073 m)	80.125" (2.035 m)

Use Figure 5 to select the tubing for each element. If you previously sorted the tubing, this step will be much easier. Each element uses two identical element halves; assemble both halves of each element at the same time.

Accurately measure the exposed tubing lengths as shown in Figure 6, starting at the boom end of one of the element halves. In Figure 6, metric dimensions are shown on the left and American dimensions are shown on the right. Tighten the appropriate clamp after each measurement. Repeat for the other element half. Double-check all the measurements before you proceed. You may want to mark each element half with its abbreviation (for example, 20R) so that you can easily find the correct element in later steps. Set the finished elements aside.

Repeat the preceding paragraph for each element. Remember that the 20R and the 20DE use 1-1/4" tubing with strengthening inserts at the boom end; make sure to use the correct tubing for these sections.

# ELEMENT LOCATION

# ELEMENT DESCRIPTION

(Measurements in inches)

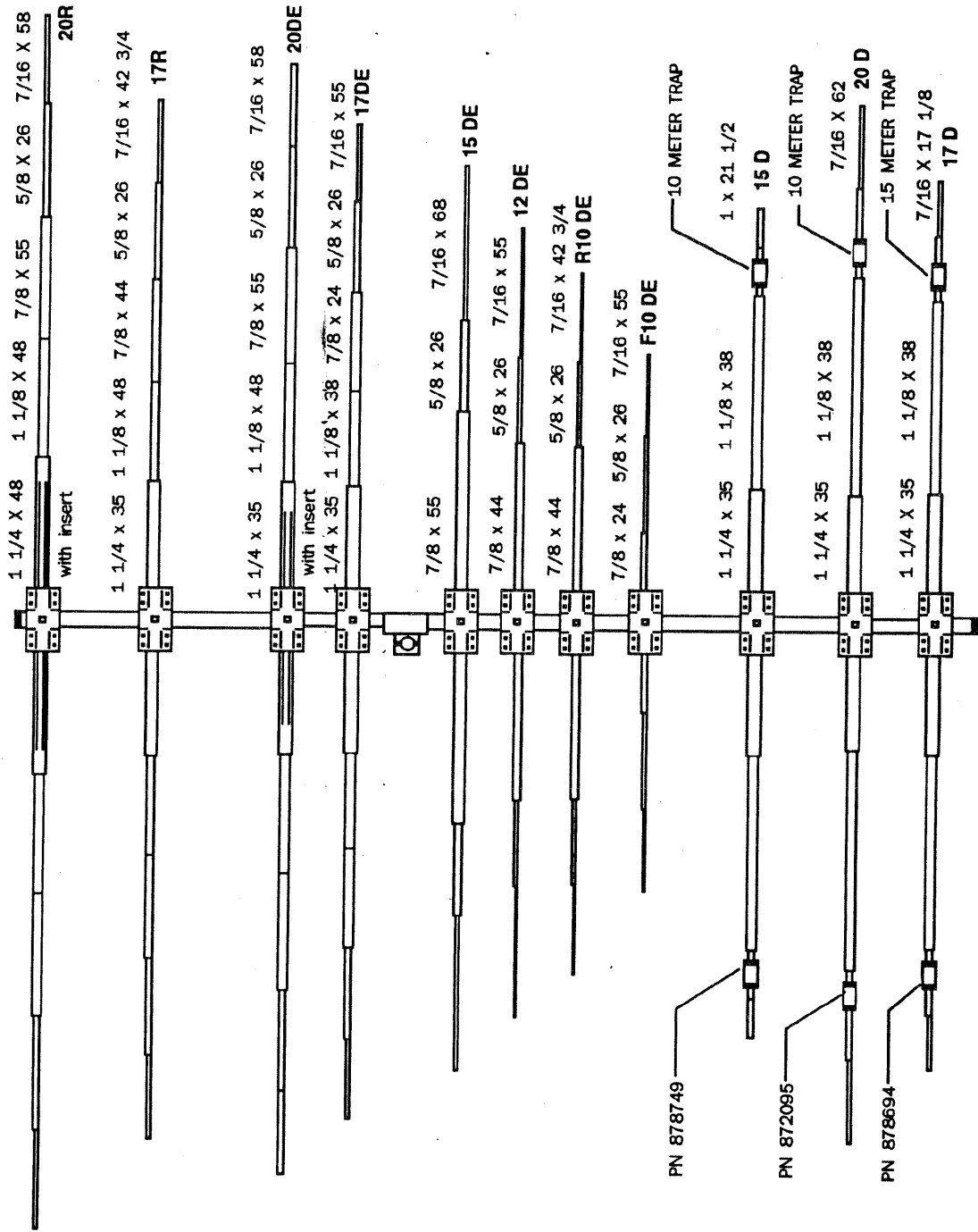

Figure 5  
Element Section Description

NOTE: See Figure 2 for Element Spacing.

398S006

METRIC (m)

AMERICAN (inches)

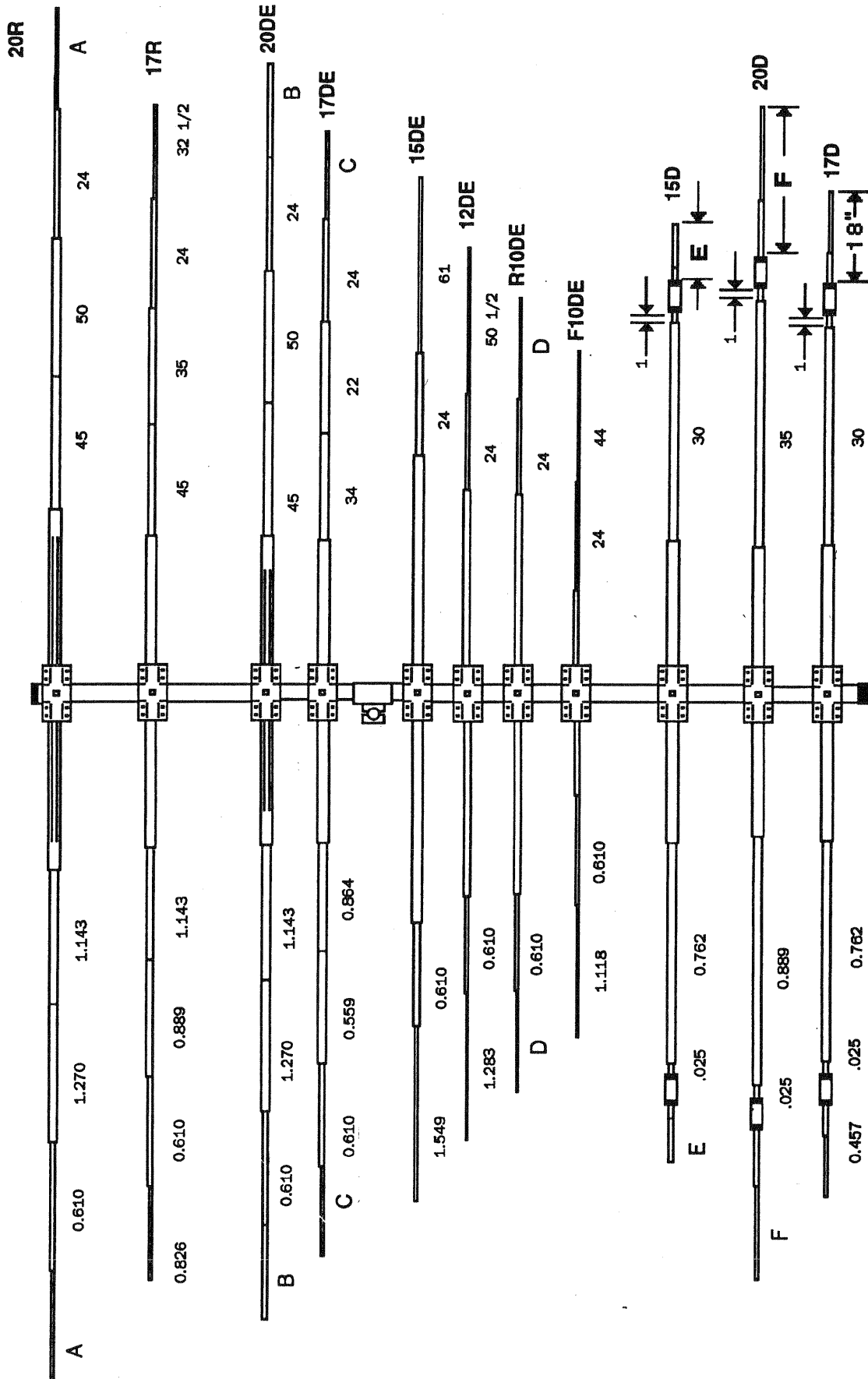
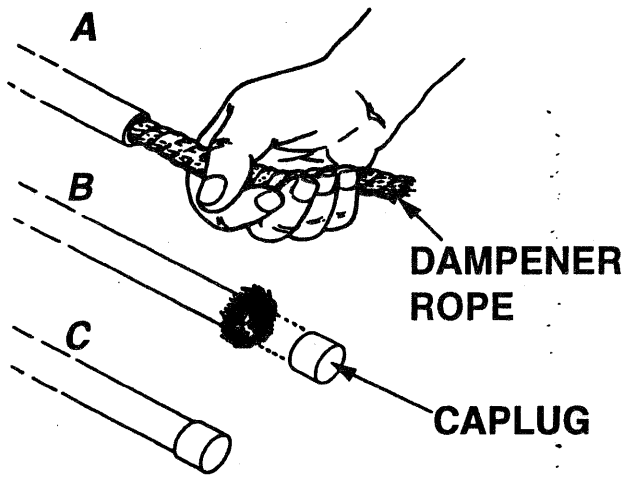
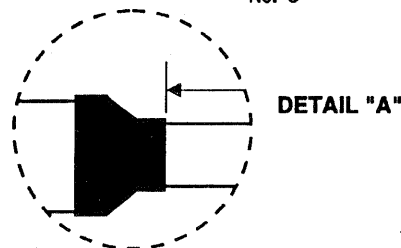
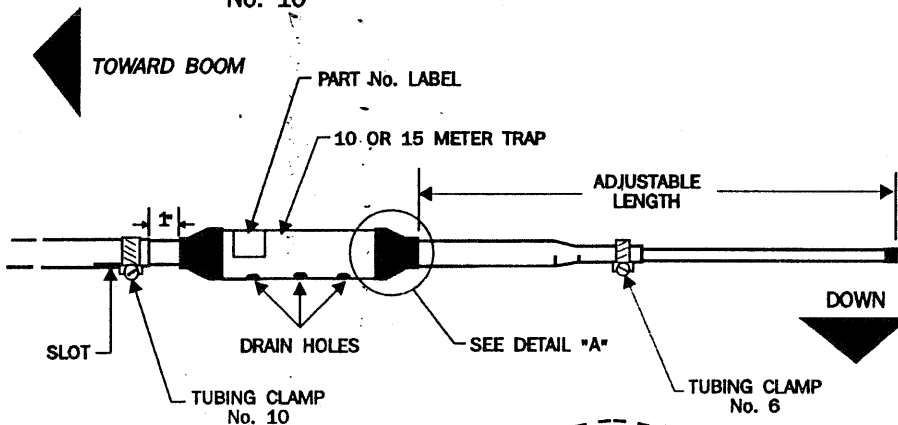
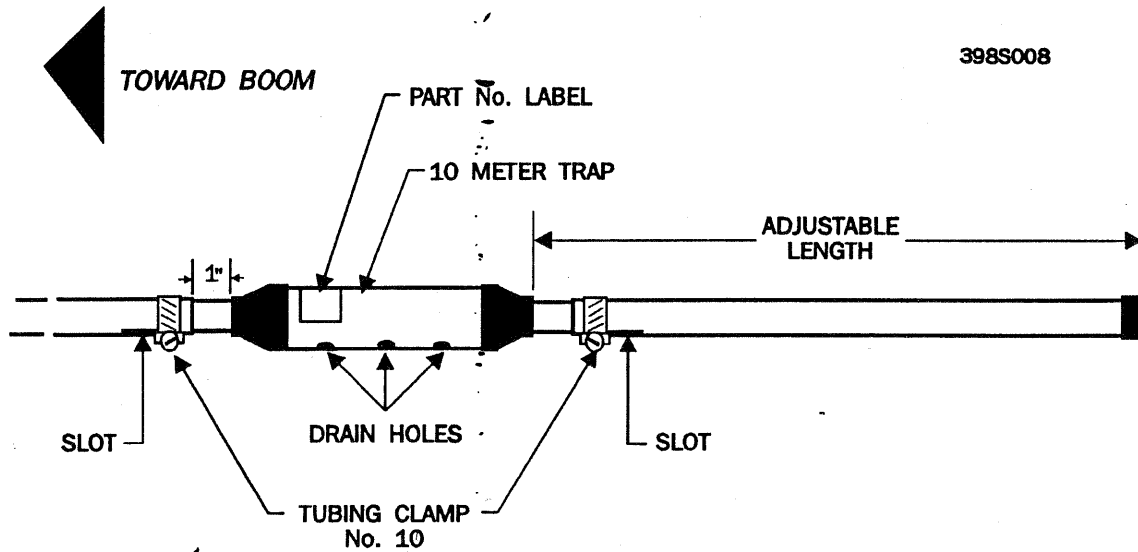

Figure 6  
Exposed Tubing Lengths and Center-to-Center  
Element Spacing



**Figure 7**  
**Rope Dampener**

The two reflectors and the six driven elements require dampener rope in the last tubing section (the 7/16" tubing at the end of the element). This rope prevents low-frequency oscillations that may occur at low wind speeds. Select the dampener rope (Item 83) and cut it into sixteen (16) equal lengths of 45" (1.14m) each. Slip one length of rope into the outside end (the 7/16" tube) of an element half. With about 1/2" (13mm) of rope extending from the element half, fray the rope into individual fibers, and then fold the fibers back along the outside of the tube. See Figure 7. Slip a 7/16" caplug over the element end and rope fibers and push the caplug so that it is secure. Repeat this procedure for each of the sixteen element halves for the reflectors and driven elements.



**Figure 8**  
**Trap Detail**



The driven elements have insulators on the boom end. The 20DE and 17DE use a larger insulator than the other four elements. Select the driven element insulators and install them on each of the twelve driven element halves. Make sure that the insulators are pushed all the way on the element halves.

**When you assemble the trapped director elements, make sure that the trap drain holes face the ground and that the trap part number labels are on the boom end of the traps.** Also, on all tubing attached to the traps, make sure that all slots are facing the ground and that the small drain holes are aligned with the slots. Make sure all trap-cap insulators are firmly seated against the trap before measuring the dimensions. See Figure 8. Install 7/16" and 1" caplugs on the ends of the remaining elements. Select the 2" caplugs and place one on each boom end. Double check the exposed tubing measurements against Figure 6.

### **Installing Elements on the Boom**

You should now have 22 completely assembled element halves. Insert the 15DE element halves into the 15DE element-to-boom brackets, and then tighten the eight 1/4"-20 x 3/4" bolts until it is difficult to rotate the bracket on the boom (make sure the anchor bolt on the bottom of the bracket is very loose!). Align the 15DE so that it is parallel to the ground and perpendicular to the temporary mast (which is perpendicular to the ground). If you have a flat assembly area, you can use visual references, such as corners of structures and horizontal lines in exterior walls, to align the element. You can also ask a helper to hold a carpenter's square against the temporary mast as you "eyeball" the horizontal alignment. It is important to position the boom as parallel to the ground as possible. This will ease the element installation and minimize orientation of the elements during the boom support assembly. When the element is aligned, securely tighten the eight 1/4"-20 x 3/4" bolts and the anchor bolt.

Attach the other elements to the boom by repeating the preceding paragraph. It's easier to keep the antenna balanced if you install elements on alternate sides of the boom, working out toward the ends of the boom. For example, install the 17DE next, then 12DE, then 20DE, and so on. Remember to align each element in the horizontal plane (you can get the first element aligned and then compare the other elements to the first). Securely tighten the eight 1/4"-20 x 3/4" bolts on each element and the anchor bolt (or two anchor bolts on the 20R, 17R, 20DE, F10DE, 15D, 20D, and 17D) on each element. After all elements are installed and aligned, check that the element-to-boom brackets are still spaced on the boom according to Figure 2.

### **Phasing Tube Assembly**

Select the two (2) 3/4" x 52 1/2" phasing tubes (Item No. 18), two (2) 3/4" x 45 1/2" phasing tubes (Item No. 17), two (2) 7/8" x 2" splice tubes (Item No. 12), the pigtail wire assemblies, support clamps and insulators, and hardware as shown in Figure 9. Assemble the tubes together as shown, using four (4) 10-24 x 1 1/4" hex head screws, #10 internal-tooth lockwashers, #10 split lockwashers, and 10-24 hex nuts (Item Nos. 41, 46, 42, and 44) Install a 6 1/2" pigtail wire (Item No. 65) on the rear joint of each tubing assembly before tightening the hardware. Install the remaining 6 1/2" pigtail wires in the front three (3) holes of each tubing assembly as shown, using #10 hardware. The #10 solder lug of each wire assembly should be sandwiched between the split and internal-tooth lockwashers or between the screw head and the split lockwasher as shown. This minimizes galvanic corrosion, and ensures good long-term electrical contact. Install the four (4) 9 1/2" pigtail wires (Item 58) in the rear two (2) holes of each tubing assembly as shown, using #10 hardware. Use the same assembly method as before. Before tightening the hardware, position the pigtail wires as shown.

**NOTE:** The pigtail wires must alternate from crossed to not-crossed, starting at the front of the phasing tube assembly and progressing toward the rear. This is the normal configuration of a Log-Periodic Dipole Array (LPDA). Make sure you follow the pigtail configurations of Figures 10 and 11.

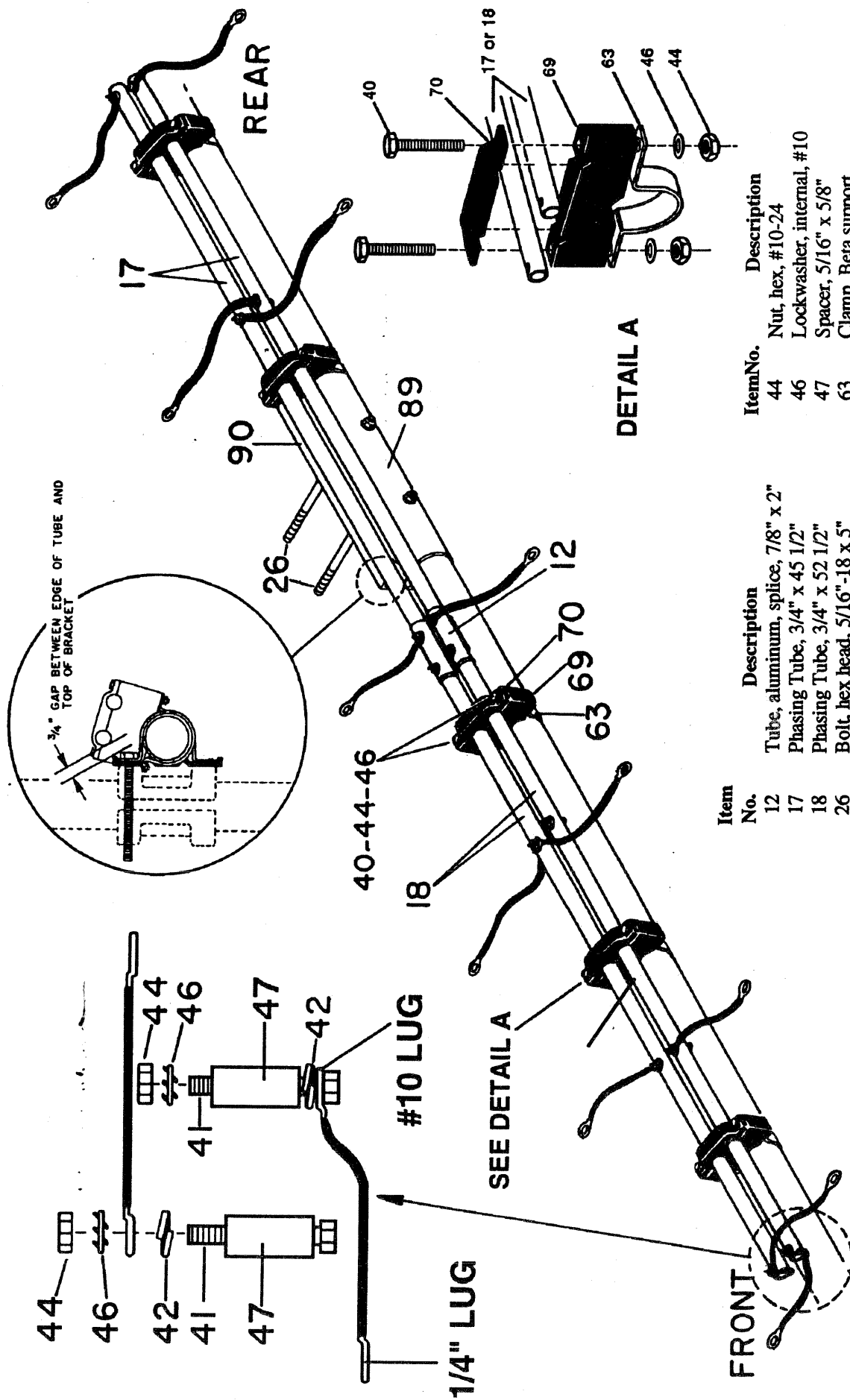

Item No.	Description
44	Nut, hex, #10-24
46	Lockwasher, internal, #10
47	Spacer, 5/16" x 5/8"
63	Clamp, Beta support
69	Insulator, Beta Support (Bottom)
70	Insulator, Beta support (Top)
89	Clamp, Boom-to-Bracket
90	Bracket, Casting-to-Boom

Item No.	Description
12	Tube, aluminum, splice, 7/8" x 2"
17	Phasing Tube, 3/4" x 45 1/2"
18	Phasing Tube, 3/4" x 52 1/2"
26	Bolt, hex head, 5/16"-18 x 5"
40	Bolt, hex head, #10-24 x 2"
41	Bolt, round head, #10-24 x 2"
42	Lockwasher, #10 Split

**NOTE:** The spacing between pigtail wire sets should match the spacing between elements, except for the 20 DE pigtail wire. See Figure 2. The spacing between the 17 DE and 20 DE pigtail wires should be 20 1/2".

**Figure 9**  
Phasing Tube Assembly

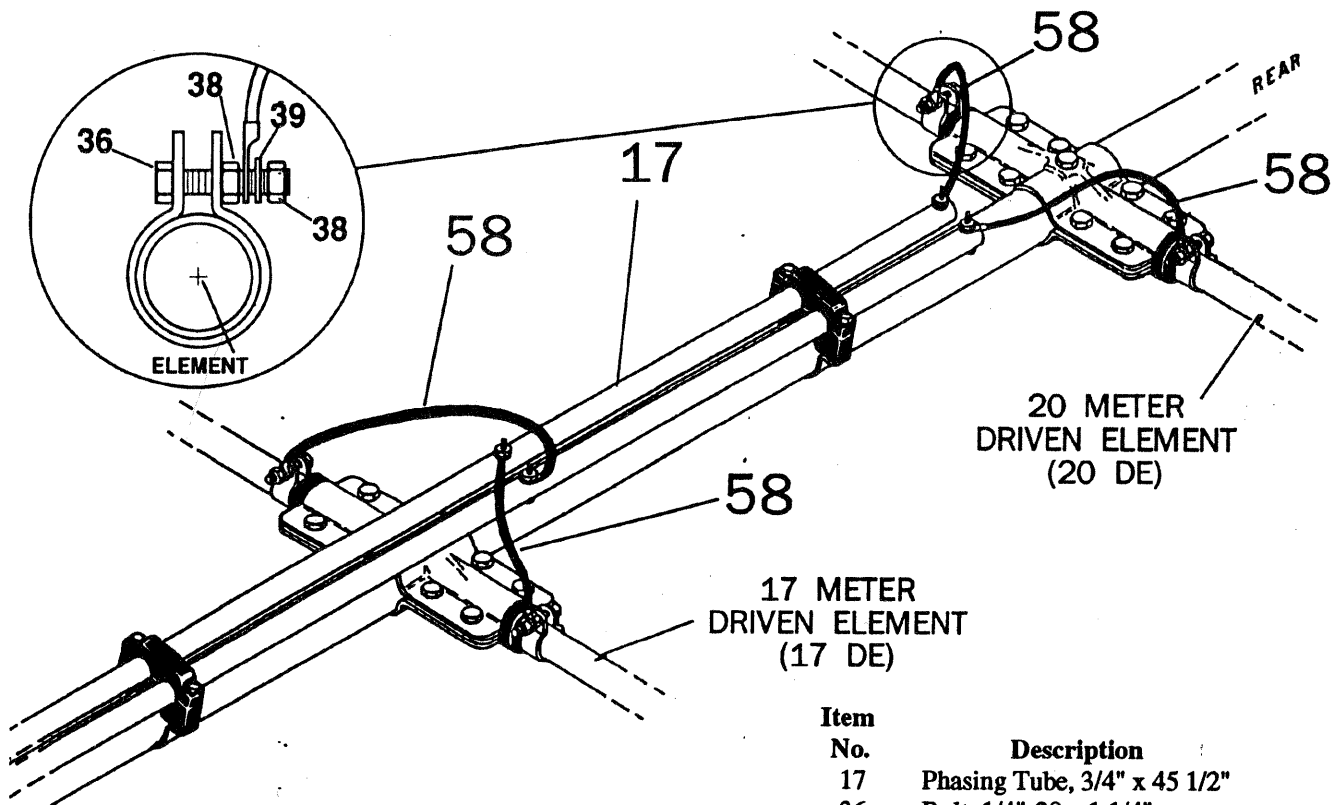

17 METER  
DRIVEN ELEMENT  
(17 DE)

20 METER  
DRIVEN ELEMENT  
(20 DE)

Item No.	Description
17	Phasing Tube, 3/4" x 45 1/2"
36	Bolt, 1/4"-20 x 1 1/4"
38	Nut, hex head, 1/4 x 20
39	Lockwasher, internal, 1/4"
58	Pigtail Wire, 9 1/2"

**Figure 10**  
**20 and 17 Meter Pigtail Wire Attachment**

Select the five (5) sets of support clamp (Item 63), bottom support insulator (Item 69), top support insulator (Item 70), 10-24 x 2" screws, #10 internal-tooth lockwashers, and 10-24 hex nuts as shown in the detail for figure 9. Assemble these loosely to the phasing tube assemblies and boom as shown.

If you **did not** use a temporary mast, rotate the phasing tube assembly on the boom and install the top two mast bracket bolts (5/16 - 18 x 5") as shown in Figure 9. Rotate the assembly back into place and position them so that the closest phasing tube is 3/4" from the top flange of the mast bracket. You should be able to insert your fingers between the phasing tube and mast bracket. Slide the support clamps along the boom until the front of the phasing tubes is 2 3/4" from the center of the F10DE bracket. Ensure that both tubes are even and that the pigtail wire attachment screws are vertical.

Tighten the hardware on all phasing tube support clamps securely.

Select the 1/4" -20 x 1 1/4" screws, lockwashers, and hex nuts and attach the four 9 1/2" pigtail wires to the aluminum tubing clamps on 20DE and 17DE as shown in Figure 10. Tighten the hardware securely. Select the 1/4" - 20 x 1" screws, lockwashers, and hex nuts and attach the eight 6 1/2" pigtail wires to the aluminum tubing clamps on 15DE, 12DE, F10DE, and R10DE as shown in Figure 11. Also attach the two 5 3/4" pigtail wires to the clamps on F10DE. These will attach to the balun. Tighten all hardware securely.

Attach the BN-4000 balun to the boom, as in Figure 11, using the U-bolt and #10 - 24 nuts. Attach the two 5 3/4" pigtail wires to the balun using 1/4" - 20 x 3/8" screws and lockwashers. Tighten all hardware securely.

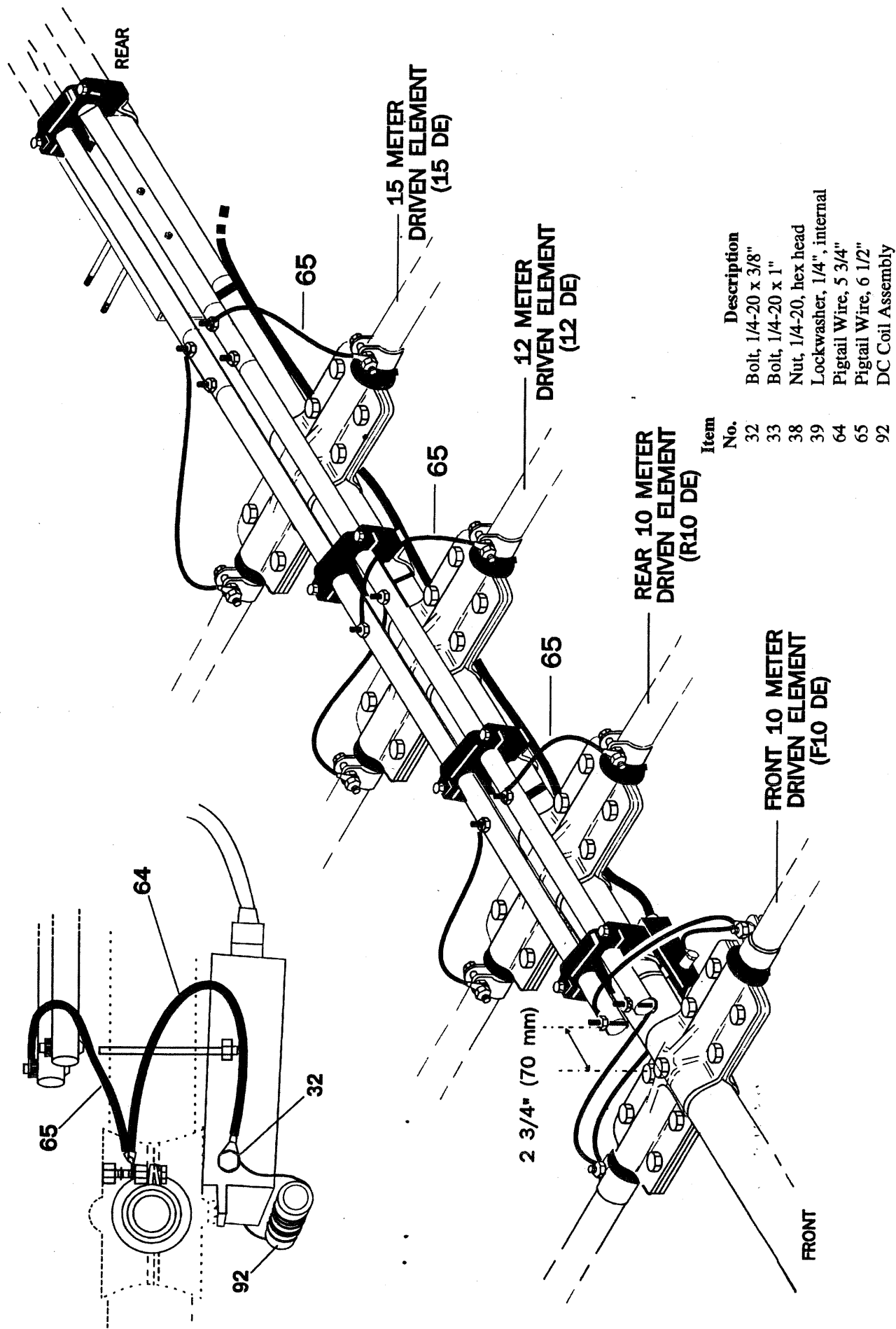

Item No.	Description
32	Bolt, 1/4-20 x 3/8"
33	Bolt, 1/4-20 x 1"
38	Nut, 1/4-20, hex head
39	Lockwasher, 1/4", internal
64	Pigtail Wire, 5 3/4"
65	Pigtail Wire, 6 1/2"
92	DC Coil Assembly

Figure 11  
10, 12, 15 Meter Pigtail Wires and Balun Attachment

## Boom Support Assembly

Select the two 2" I.D. boom support clamps (Item No. 78), two cable assemblies (Item No. 81), two mast guy straps (Item No. 76), four 1/4" - 20 x 3/4" screws, 1/4" lockwashers, and 1/4" - 20 hex nuts. Assemble one clamp and cable to each end of the boom at 103" from the center of the boom-to-mast clamp as shown in Figure 12.

Attach one mast guy strap to the free end of each cable assembly. Securely tighten only the boom clamps at this time. Route both cable assemblies above all elements and tape near the boom-to-mast bracket so they can be reached after the antenna has been mounted on the tower.

**NOTE:** You may wish to temporarily attach the mast guy straps to your temporary mast to check for equal tension in each cable. Move one of the boom clamps if required and retighten.

398S009

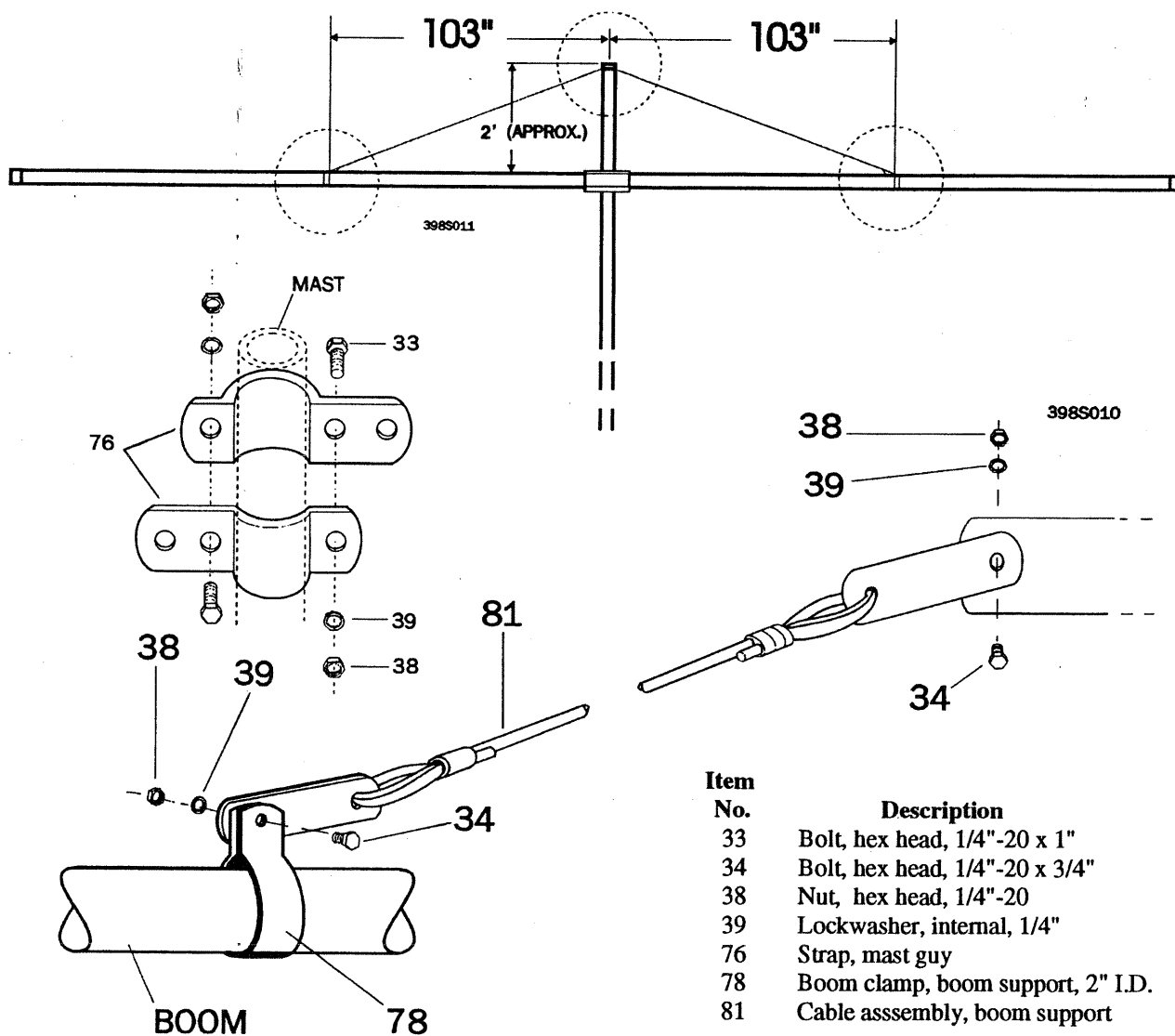

**Figure 12**  
**Boom Support Assembly**



# CHAPTER 4

## Antenna Installation

Make sure all element tubing clamps and anchor bolts are securely tightened. Also, make sure all phasing tube hardware is secure. Ensure that all trap drain holes are facing the ground.

### IMPORTANT

The TH11DX is a large and heavy antenna and requires some consideration as to how you are going to get it to the top of the tower. Thoroughly read this section before beginning to install your antenna.

## Installation On a Crank-Up Tower

Crank the tower completely down or as low as it will go and block all sections from moving by using a 2" x 4" piece of wood or a solid iron bar for heavier towers. The block should be inserted through the lattice structure before the tower is completely down, then the tower can be cranked down until the block takes the weight off of the winch.

### WARNING

Installation of this product near power lines is dangerous! For your safety, follow the instructions provided with your tower and the instructions in this manual.

Use a ladder to reach the top of the tower. **NEVER CLIMB THE LATTICE STRUCTURE OF ANY CRANK-UP TOWER!** Attach the mast to the tower and rotator. (The cast aluminum boom-to-mast brackets should be removed from the temporary mast and installed on the permanent mast as shown in Figure 1.) Attach a gin pole to the tower or mast to assist in lifting the antenna.

## Other Types of Towers

When installing the TH11DX on a guyed tower, you may wish to use a guide system. If you have insulators on your guy wires, you will need to keep the antenna away from the guy wires as well as the tower. You can use two ropes attached together at the top of the tower and attached to the ground about 15 to 20 feet apart. These two ropes can then be used to slide the antenna on as it is also being lifted. The two ropes will need to be far enough from the tower base to allow some sag and still support the antenna away from the guy wires. Remember that this antenna weighs 88 pounds!

## Attachment of Feedline

Use a good quality 50 ohm coaxial transmission line such as Times RG-213/u (solid), Belden 8267 (solid). Belden 9913 is NOT recommended! Take extra care when soldering connectors to foam dielectric coaxial cable. Weatherproof all connectors which will be exposed to rain or ice, with Coax-Seal (R) or another similar substance.

Attach the transmission line to the BN-4000 balun and tighten the connector securely. Tape the coax to the boom in at least two places and weatherproof the connector. The cable will be lifted with the antenna, so ensure good strain relief.

## Attaching the Antenna to the Mast

Attach the lifting rope to the balance point of the antenna. Be careful not to damage the phasing line assembly next to the boom-to-mast clamp. The bolt holding the support insulator near the boom-to-mast bracket may be loosened before lifting and retightened after the antenna is installed. The lifting rope should be fed through the gin pole or other pulley arrangement attached to the tower. The other end should be at ground level, available to the ground crew for lifting. Guide ropes may be loosely looped over the boom ends and used by the ground crew to guide the antenna away from the tower, guy wires or ladder. The guide rope's two loose ends should be held by the ground crew, so that the guide rope can be retrieved.

When the antenna reaches the mast bracket, the top two 5" bolts should be inserted through the top two holes in the mast bracket and secured using 5/16" - 18 lockwashers and nuts. The other two remaining 5/16" - 18 x 5" bolts should now be installed and secured with lockwashers and nuts. Tighten all bolts securely. You may wish to use a deep-well socket set to tighten these bolts. The bolt heads must be on the same side of the boom-to- mast brackets as the phasing tubes. See Figures 1 and 9.

The boom support cables may now be untaped from the boom and attached to the mast. Slide the entire assembly up the mast until the boom support wires are straight and the boom is level. Tighten all bolts securely! Tape the coax to the mast, leaving a loop for rotation. Check the direction of the antenna for use in calibrating your rotator.

### Lightning Protection

For proper lightning protection, you must ground your antenna supporting structure. Grounding will ensure noise free operation and low VSWR. A proper ground consists of a 1/2" x 8' copper clad steel ground rod driven into the ground approximately 12" away from the concrete tower base. Connect the tower to the ground rod using #8 copper wire and commercial non-corrosive ground clamps.

An optional DC-grounding coil may be placed across the balun terminals to dissipate rain static.

### VSWR Curves

These VSWR curves are typical for the antenna mounted 70 feet above the ground, horizontally polarized and fed with 100 feet of RG-213/u cable. Similar curves can be expected for this antenna mounted between 40 and 100 feet above the ground. **DO NOT TRY TO TUNE THIS ANTENNA FOR LOW VSWR AT GROUND LEVEL.** Higher VSWR can be expected if mounted at less than 30 feet or above a roof or large metallic structure. Forty (40) and eighty (80) meter wire dipoles should be kept at least 6 feet below this antenna. Guy wires should be broken up into non-resonant lengths (less than 12 foot lengths) and insulated from the tower if mounted within 10 feet of the top of the tower. Forty (40) and thirty (30) meter beams should be kept at least 10 feet above or below the TH11DX.

Extreme care must be used if you use an air-dielectric coax cable such as Belden 9913. Water intrusion can easily raise the VSWR and loss.

Telex/Hy-Gain recommends the Bird Model 43 directional watt meter to measure reflected power and VSWR. This meter with the 250 watt 2-30 MHz element will give the most accurate information.

398Sform

$$K = \sqrt{\frac{\text{Refl. Power}}{\text{Forward Power}}}$$

$$\text{VSWR} = \frac{1 + K}{1 - K}$$



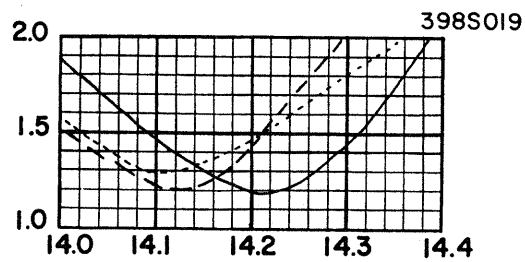
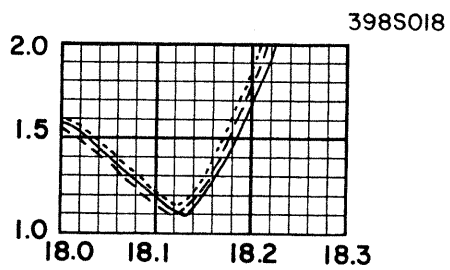
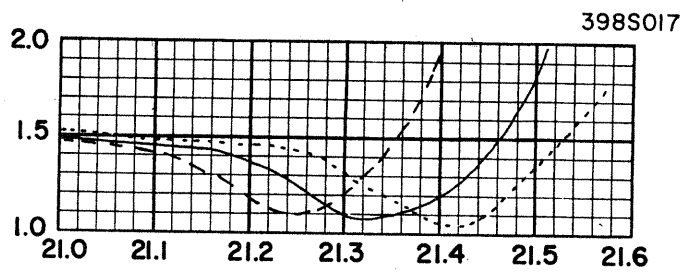
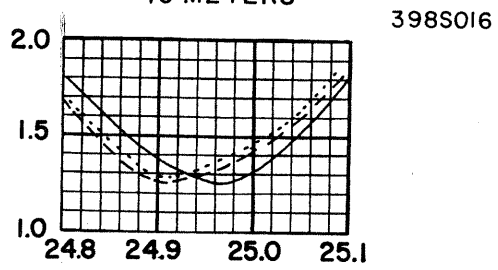
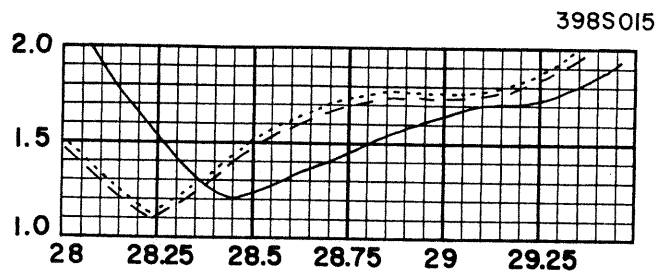

— PHONE  
 - - - DX  
 ..... MARS

VSWR Charts



# CHAPTER 5

## Operation

Connect the other end of your transmission line to a good quality SWR meter and then to your transmitter. While using low power (less than 100 watts output), check the VSWR across each band from 14.0 to 29.7 MHz. Record this information for future comparison. See Table 1. Check the VSWR periodically to ensure proper operation.

The gain of your system may be checked by comparing your transmitted signals with those from another similarly equipped station nearby. The other station must not be more than 5 miles distant or be at a different elevation. The receiving station should be at normal skip distance.

The front-to-back ratio may be checked by using a steady carrier transmitted by a local station at least 1 mile distant. The front-to-back ratio may be affected by the proximity of metallic structures or guy wires less than 10 feet below the antenna. Your AGC may affect your readings if the signal is very strong.

This completes your installation of the Telex / Hy-Gain TH11DX antenna. Happy DX'ing!

### VSWR Record

Frequency	Type of VSWR Meter _____			
	Date _____ VSWR	Date _____ VSWR	Date _____ VSWR	Date _____ VSWR
14.00	_____	_____	_____	_____
14.10	_____	_____	_____	_____
14.20	_____	_____	_____	_____
14.30	_____	_____	_____	_____
14.35	_____	_____	_____	_____
18.10	_____	_____	_____	_____
21.00	_____	_____	_____	_____
21.10	_____	_____	_____	_____
21.20	_____	_____	_____	_____
21.30	_____	_____	_____	_____
21.40	_____	_____	_____	_____
21.45	_____	_____	_____	_____
24.90	_____	_____	_____	_____
28.00	_____	_____	_____	_____
28.25	_____	_____	_____	_____
28.50	_____	_____	_____	_____
28.75	_____	_____	_____	_____
29.00	_____	_____	_____	_____
29.50	_____	_____	_____	_____
29.70	_____	_____	_____	_____

## Maintenance

The TH11DX antenna is designed to be relatively maintenance free for most environments. All hardware is made of passivated stainless steel, typically grade 304. The internal tooth-type lockwashers used in this antenna are grade 410 stainless steel, and are slightly magnetic. The element tubing clamps are grade 304 stainless steel. Most other metallic parts are aluminum. All insulators exposed to sunlight are made from U.V. resistant black polyethylene or black Cylolac®.

If this antenna is installed in a highly corrosive environment, such as within one mile of salt water, several things may be done to prolong the life of this product.

Hy-Gain now recommends genuine Penetrox-A® from Burndy Corporation for use as an anti-electrolytic compound within element tubing assemblies. This prevents aluminum oxide from forming on the aluminum surface, thereby maintaining high electrical conductivity between element sections, especially in coastal environments. Penetrox-A® may be obtained from your local electrical supply store. Electro-Seal® may be used in place of Penetrox-A.

A light amount of clear lacquer or an acrylic spray may be used to coat the exterior surface of the element assemblies if heavy oxidation is likely to occur. Do not use any coating on trap assemblies.

If installed near a sea coast, the solder lugs on the pigtail wires should not touch the aluminum tube or clamp directly. Each solder lug should be between 2 stainless steel flatwashers. Tighten these connections securely and completely coat with Scotchkote® or RTV.

The internal tooth lockwashers should be replaced with split lockwashers of grade 304 or better stainless steel if your installation is near a sea coast. Otherwise, these lockwashers should be coated with Scotchkote® or RTV.

**NOTE:** Only use alcohol-based RTV (non-corrosive). The acid-based RTV (which releases acetic acid and smells like vinegar) will corrode metal.

When storing this antenna (or if awaiting installation), care should be taken not to damage any trap assembly or allow any dirt or insects to enter any trap assembly. Do not leave the elements in a grassy area, as wet grass will stain the aluminum.

Electro-Seal® is a registered trademark of Town and Country Plastics, Inc.  
Cylolac® is a registered trademark of Borg-Warner Chemical, Inc.  
Penetrox-A® is a registered trademark of the Burndy Corporation.  
Scotchkote® is a registered trademark of 3M

# CHAPTER 6

## Troubleshooting

If you encounter problems with the operation of your TH11DX, follow these steps to isolate the cause of your problem.

Usually you can isolate problems that occur in either your antenna or feedline/feedpoint. If you experience high VSWR on some bands but not all bands, look for problems in the antenna element lengths or traps or nearby resonant structures.

Symptom	Possible Causes
Consistently high VSWR on all bands.	<ul style="list-style-type: none"> <li>Balun damaged by lightening or excessive power.</li> <li>Shorted coaxial connector.</li> <li>Water inside of transmission line.</li> </ul>
High VSWR dependent upon direction of beam	<ul style="list-style-type: none"> <li>Resonant guy wires too close to antenna.</li> <li>Metallic structures or wiring too close to antenna.</li> </ul>
Intermittent high VSWR not dependent on weather or power level or direction of beam or band selection.	<ul style="list-style-type: none"> <li>Loose connection on feed system, matching system or transmission line.</li> </ul>
High VSWR after rainshowers or with high humidity.	<ul style="list-style-type: none"> <li>Trap(s) installed with drain holes up instead of down.</li> <li>Water inside of coax cable.</li> <li>Tubing installed with slots up instead of down.</li> </ul>
High VSWR with high power, low VSWR with low power.	<ul style="list-style-type: none"> <li>Balun damaged or defective.</li> <li>Coax cable damaged by lightning</li> </ul>
Low VSWR, but only near band edge(s).	<ul style="list-style-type: none"> <li>Loose coaxial connection on transmission line.</li> </ul>
High VSWR on only one band	<ul style="list-style-type: none"> <li>Trap(s) damaged or defective.</li> <li>Resonant guy wires or nearby metallic structure.</li> <li>Another HF antenna too close.</li> <li>Antenna not assembled correctly.</li> </ul>
High VSWR at band edges.	<ul style="list-style-type: none"> <li>Inadequate tower grounding system.</li> </ul>
15 meter resonance at 20.8 MHz	<ul style="list-style-type: none"> <li>10 meter traps turned around on 15 meter director.</li> </ul>

### Troubleshooting Chart



# CHAPTER 7

## Service Information

If you are unable to resolve your problem or if you need to order replacement parts, you should contact the Hy-Gain Customer Service Department.

You should fully research your problem by going through the Troubleshooting Guides in Chapter 6 before you contact the Customer Service Department. You should also record your VSWR across all three bands before calling

You should retain your sales receipt or other proof of purchase for antennas that are still under warranty.

All requests, inquires, warranty claims, or for ordering replacement parts, contact:

Hy-Gain  
308 Industrial Park Road  
Starkville, Mississippi 39759  
USA

Phone: 662-323-9538

FAX: 662-323-6551

### NOTES:

## Converting American Measurements to Metric

Use this scale to identify lengths of bolts, diameters of tubes, etc.. The American inch (1") and foot (1') can be converted to centimeters in this way.

1 inch (1") = 2.54 cm  
1 foot (1') = 30.48 cm

Example: 42" x 2.54 = 106.7 cm



### Bolt and Nut Sizes

To determine proper bolt diameter, place thread end of bolt over black circle. Repeat for nut.

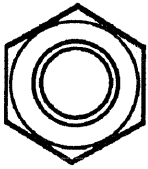

$\frac{3}{8}$  "



$\frac{5}{16}$  "



$\frac{1}{4}$  "



#10



# CHAPTER 8 - Parts List

**NOTE:** Item numbers may not necessarily be in numerical sequence.

Item No.	Part No.	Description	Qty
1	879965	Tubing Assembly, aluminum, 1 1/4" x 48".....	2
2	190300	Tube, aluminum, 1 1/8" x 48" .....	6
3	170495	Tube, aluminum, 7/16" x 62" .....	2
4	191011	Tube, aluminum, 7/8" x 55" .....	6
5	190006	Tube, aluminum, 5/8" x 26" .....	16
6	175512	Tube, aluminum, 7/16" x 42 3/4" .....	4
7	878579	Tubing Assembly, aluminum, 1 1/4" x 35".....	2
8	190307	Tube, aluminum, 1 1/8" x 38" .....	8
9	191013	Tube, aluminum, 1" x 21 1/2" .....	2
10	190908	Tube, aluminum, 1 1/4" x 35" .....	10
11	190205	Tube, aluminum, 7/8" x 44" .....	6
12	191012	Tube, aluminum, splice, 7/8" x 2" .....	2
13	171533	Tube, aluminum, 7/16" x 58" .....	4
14	190204	Tube, aluminum, 7/8" x 24" .....	4
15	174939	Tube, aluminum, 7/16" x 55" .....	6
16	170445	Tube, aluminum, 7/16" x 17 1/8" .....	2
17	179840	Phasing Tube, 3/4" x 45 1/2" .....	2
18	179841	Phasing Tube, 3/4" x 52 1/2" .....	2
19	878749	Trap, 10/12-meter.....	2
20	878694	Trap, 15-meter.....	2
21	872095	Trap, 10-meter.....	2
22	464723	Trap cap (used on all traps).....	2 per trap
23	174868	Tube, aluminum, 7/16" x 68" .....	2
	879970	<b>Parts Pack 398S, 5/16" Hardware, Stainless Steel .....</b>	<b>1</b>
24		(Not used)	
26	500349	Bolt, hex head, 5/16" - 18 x 5" .....	4
27	500392	Bolt, hex head, 5/16"-18 x 3" .....	2
28	506968	Bolt, hex head, 5/16" - 18 x 2 3/4" .....	2
29	555747	Nut, hex, 5/16"-18.....	9
30	5142400	Bolt, 5/16-18 x 4" hex head .....	1
31	564792	Lockwasher, split, 5/16" .....	9
	879971	<b>Parts Pack 398S, 1/4" Hardware, Stainless Steel .....</b>	<b>1</b>
32	500156	Bolt, hex head, 1/4" - 20 x 3/8".....	24
33	502958	Bolt, hex head, 1/4" -20 x 1" .....	10
34	505266	Bolt, hex head, 1/4" - 20 x 3/4" .....	100
35	505734	Bolt, hex head, 1/4" - 20 x 2 1/2" .....	2
36	506518	Bolt, hex head, 1/4" - 20 x 1 1/4" .....	4
37	551367	Nut, square, 1/4" - 20 .....	23
38	554099	Nut, hex, 1/4" - 20.....	122
39	562961	Lockwasher, internal, 1/4" .....	105
25	566344	Flatwasher, 1/4" .....	12

**Parts List (Continued)**

<b>Item No.</b>	<b>Part No.</b>	<b>Description</b>	<b>Qty</b>
	879972	<b>Parts Pack 398S, #10 Hardware, Stainless Steel .....</b>	<b>1</b>
40	500157	Bolt, hex head, #10 - 24 x 2" .....	10
41	500159	Bolt, hex head, #10 - 24 x 1 1/2" .....	14
42	561178	Lockwasher, #10 split .....	14
43		(Not Used)	
44	554071	Nut, hex, #10 -24 .....	28
45		(Not Used)	
46	565697	Lockwasher, internal, #10 .....	24
47	179874	Spacer, 5/16" x .058 x 5/8" .....	4
48 - 51		(Not used)	
	879968	<b>Parts Pack 398S, Clamps.....</b>	<b>1</b>
52	358756	Clamp, Tubing No. 6 .....	40
53	358757	Clamp, Tubing No. 10 .....	16
54	358758	Clamp, Tubing, No. 16 .....	14
55	169339	Clamp, Tubing, 7/8".....	8
56	168695	Clamp, Tubing, 1 1/4".....	4
57	540087	U-bolt, #10-24 x 2 1/2" x 2 3/4" .....	1
58	879973	Pigtail Wire, 9 1/2" .....	4
59 - 62		(Not used)	
63	177888	Clamp, Support.....	5
64	879974	Pigtail Wire, 5 3/4" .....	2
65	878561	Pigtail Wire, 6 1/2" .....	8
66		(Not used)	
	879969	<b>Parts Pack 398S, Insulators.....</b>	<b>1</b>
67	455625	Caplug, 2" .....	2
68	455644	Caplug, 7/16" .....	20
69	465595	Insulator, Support (Bottom).....	5
70	465600	Insulator, Support (Top).....	5
71	465833	Insulator, Driven Element.....	4
72	463767	Insulator, Driven Element.....	8
73	450401	Caplug, 1" .....	2
74-75		(Not used)	
	879967	<b>Parts Pack, Boom Support.....</b>	<b>1</b>
76	380862	Strap, Mast Guy, HDG.....	2
77		(Not Used)	
78	378208	Boom Clamp, 2", 16 GA.....	2
79	872098	Tube, Boom, 2" x 79 1/2" .....	2
80	879915	Balun, BN-4000 .....	1
81	879966	Cable Assembly, Boom Support.....	2
82	102734	Mast Bracket, cast aluminum .....	2
83	690190	Rope, dampener, 5/32" .....	60 feet
84	165919	Bracket, Element-to-Boom, #13 .....	18
85	165920	Bracket, Element-to-Boom, #14 .....	4
86 & 87		(Not used)	

**Parts List (Continued)**

<b>Item No.</b>	<b>Part No.</b>	<b>Description</b>	<b>Qty</b>
88	171166	Tube, Boom, 2" x 69 1/2" .....	2
89	172732	Clamp, Boom-to-Bracket .....	1
90	172735	Bracket, Casting-to-Boom .....	1
91	850050	Coax-Seal® .....	1
92	870305	DC coil assembly .....	1
93	850091	Penetrox®A-3 .....	1

Coax-Seal® is a registered trademark of Universal Electronics, Inc.

Penetrox® is a registered trademark of the Burndy Corporation

## **hy-gain**® LIMITED WARRANTY

*hy-gain* Warrants to the original owner of this product, if manufactured by *hy-gain* and purchased from an authorized dealer or directly from *hy-gain* to be free from defects in material and workmanship for a period of 12 months for rotator products and 24 months for antenna products from date of purchase provided the following terms of this warranty are satisfied.

1. The purchaser must retain the dated proof-of-purchase (bill of sale, canceled check, credit card or money order receipt, etc.) describing the product to establish the validity of the warranty claim and submit the original or machine reproduction of such proof-of-purchase to *hy-gain* at the time of warranty service. *hy-gain* shall have the discretion to deny warranty without dated proof-of-purchase. Any evidence of alteration, erasure, or forgery shall be cause to void any and all warranty terms immediately.
2. *hy-gain* agrees to repair or replace at *hy-gain's* option without charge to the original owner any defective product under warranty, provided the product is returned postage prepaid to *hy-gain* with a personal check, cashiers check, or money order for \$8.00 covering postage and handling.
3. Under no circumstances is *hy-gain* liable for consequential damages to person or property by the use of any *hy-gain* products.
4. Out-of-warranty Service: *hy-gain* will repair any out-of-warranty product provided the unit is shipped prepaid. All repaired units will be shipped COD to the owner. Repair charges will be added to the COD fee unless other arrangements are made.
5. This warranty is given in lieu of any other warranty expressed or implied.
6. *hy-gain* reserves the right to make changes or improvements in design or manufacture without incurring any obligation to install such changes upon any of the products previously manufactured.
7. All *hy-gain* products to be serviced in-warranty or out-of-warranty should be addressed to ***hy-gain*, 308 Industrial Park Road, Starkville, Mississippi 39759, USA** and must be accompanied by a letter describing the problem in detail along with a copy of your dated proof-of-purchase.
8. This warranty gives you specific rights, and you may also have other rights which vary from state to state.